

# Acuvim II Series High Performance Meters

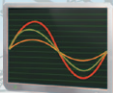

Waveform  
Capture



Real Time  
Metering



Email



Data Logging



TOU

**Max &  
Min**

Max & Min  
Record



- Revenue Grade with Data Logging
- Waveform Capture
- DNP 3.0
- BACnet



ISO9001 Certified

**ACCUENERGY**

# Acuvim II Series High Performance Meters



*100ms Refresh*

*0.2 Class*

*400 Parameters*

*DNP 3.0*

*BACnet*

*16 MB Memory*

*NEMA 3*

*5 Year Warranty*

## DESCRIPTION

The Acuvim II series are high-end multifunction power and energy meters manufactured by Accuenergy. They are the ideal choice for the monitoring and controlling of power distribution systems.

The Acuvim II series may be used as data gathering devices for intelligent power distribution systems or plant automation systems. All monitored data is available via a digital RS485 communication port running Modbus RTU and DNP 3.0 protocols, additional communication options include: Modbus, Ethernet, Profibus DP, and BACnet.

With its flexible, modular I/O and communication options, the Acuvim II series is the most versatile and cost-effective metering solution on the market.

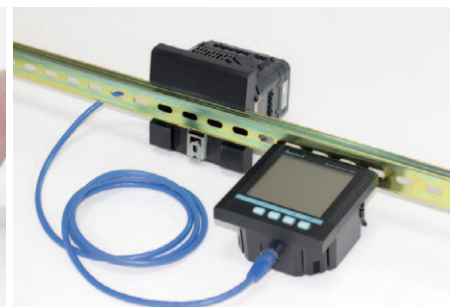

Top quality components are meticulously engineered into a line of products offering best-in-class capability that exceeds the toughest standards and ratings.

- 100ms Refresh, True-RMS Measuring Parameter
- ANSI C12.20 (0.2 Class) and IEC 62053-22 (0.2S Class)
- 16 MB Onboard Memory
- Power Quality Analysis
- Over/Under Limit Alarm
- Multiple Communication Ports (E.g: Ethernet, RS485)
- Supports Modbus RTU, DNP 3.0, BACnet IP, BACnet MS/TP
- Web Server and Email Sending, SNMP
- Switch Status Monitoring
- Waveform Capture
- Measure Individual Harmonics from 2<sup>nd</sup> to 63<sup>rd</sup>
- Physical Anti-Tampering Seal
- 50/60Hz and 400Hz Rated Frequency Metering
- Modular Design
- Data Logging
- TOU, 4 Tariffs, 12 Seasons, 14 Schedules
- Class Leading Warranty



## APPLICATIONS

Submeters for high performance monitoring and analysis, system integration & speciality applications.

- Metering of Distribution Feeders, Transformers, Generators, Capacitor Banks and Motors
- Medium and Low Voltage Systems
- Commercial, Industrial, Utility
- Power Quality Analysis
- Data Logging



# FEATURES

## Metering

- Voltage V1, V2, V3, Vlnavg, V12, V23, V31, Vllavg
- Current I1, I2, I3, In, Iavg
- Power P1, P2, P3, Psum
- Reactive Power Q1, Q2, Q3, Qsum
- Apparent Power S1, S2, S3, Ssum
- Frequency F
- Power Factor PF1, PF2, PF3, PF
- Energy Ep\_imp, Ep\_exp, Ep\_total, Ep\_net, Epa\_imp, Epa\_exp, Epb\_imp, Epb\_exp, Epc\_imp, Epc\_exp
- Reactive Energy Eq\_imp, Eq\_exp, Eq\_total, Eq\_net, Eqa\_imp, Eqa\_exp, Eqb\_imp, Eqb\_exp, Eqc\_imp, Eqc\_exp
- Apparent Energy Es, Esa, Esb, Esc
- Demand Dmd\_P, Dmd\_Q, Dmd\_S, Dmd\_I1, Dmd\_I2, Dmd\_I3
- Load Features
- Four Quadrant Powers

## Monitoring

- Power Quality
- Voltage Harmonics 2<sup>nd</sup> to 63<sup>rd</sup> and THD
- Current Harmonics 2<sup>nd</sup> to 63<sup>rd</sup> and THD
- 400Hz type, only support 2<sup>nd</sup> to 15<sup>th</sup>
- Voltage Crest Factor
- THFF (TIF)
- Current K Factor
- Voltage Unbalance Factor U\_unbl
- Current Unbalance Factor I\_unbl
- Max/Min Statistics with Time Stamps

## Alarms

Limits can be set for up to 16 indicated parameters and can be set with a specified time interval. If any input of the indicated parameters is over or under its setting limit and persists over the specified time interval, the event will be recorded with time stamps and trigger the Alarm DO output. The 16 indicated parameters can be selected from any of the 80 parameters available.

## I/O Option Module

The E-module® technique was adopted for its flexibility and easy expansion of the I/O function of Acuvim II. A maximum of 3 modules can be used for one meter. Digital input, digital output, pulse output, relay output, analog input and analog output are provided by I/O option module.

## Anti-tampering Seal

Users can physically seal the meter similar to a utility meter in order to provide anti-tampering protection. All metrological programming and user-defined parameters are protected with a physical seal.

## High Frequency Metering

Designed for use with 400Hz aircraft systems Acuvim II series power meters effectively monitors any airborne system.

# MULTI-PLATFORM ACCESS

Built-in web server provides computer, tablet and smartphone access.



## Data Logging

Acuvim IIR/IIIE/IIW offers 3 assignable historical logs where the majority of the metering parameters can be recorded. The onboard memory is up to 8 MB and each log size is adjustable. A real time clock allows for any logged events to be accurately time stamped.

## Time of Use

Users can assign up to 4 different tariffs (sharp, peak, valley and normal) to different time periods within a day according to the billing requirements. The Acuvim IIE meter will calculate and accumulate energy to different tariffs according to the meter's internal clock timing and TOU settings.

## Waveform Capture

Acuvim IIW can record 100 groups of voltage and current waveforms. It provides the waveform record of 10 cycles before and after the triggering point. It also supports a settable triggering condition.

## Power Quality Event Logging

When a power quality event happens, such as voltage sag and swell, etc., Acuvim IIW will record the timestamp and the triggering condition of the event. It can save up to 50, 000 power quality events.

## Automatic Frequency adaptation

Rated frequency is adjusted automatically to local frequency such as 50Hz or 60Hz. The same meter can be used in countries with different electrical frequencies.

## Flexible Current Input

Compatible with different current transformers such as 5A, 1A, 80mA, 100mA, 200mA, 333mV output CT and Rogowski coil all available from Accuenergy.

## Communication

- Modbus RTU Protocol and DNP 3.0 via RS485
- Ethernet (Modbus TCP, HTTP, SMTP, SNMP)
- Profibus DP
- BACnet IP, BACnet MS/TP
- Dual RS485 Communication Ports

## Display

- Clear and Large Character LCD Screen Display with White Backlight
- Wide Environmental Temperature Endurance
- Display Load Percentage, 4 Quadrant Powers, and Load Nature

## Outline

Small Size 96×96 DIN or 4" ANSI Round



# FUNCTION LIST



● Function; ⊙ Option; Blank NA

CATEGORY		ITEM	PARAMETERS	Acuvim II	Acuvim IIR	Acuvim IIE	Acuvim IIW
METERING	REAL TIME METERING	Phase Voltage	V1, V2, V3, Vlnavg	●	●	●	●
		Line Voltage	V12, V23, V31, Vllavg	●	●	●	●
		Current	I1, I2, I3, In, Iavg	●	●	●	●
		Power	P1, P2, P3, Psum	●	●	●	●
		Reactive Power	Q1, Q2, Q3, Qsum	●	●	●	●
		Apparent Power	S1, S2, S3, Ssum	●	●	●	●
		Power Factor	PF1, PF2, PF3, PF	●	●	●	●
		Frequency	F	●	●	●	●
		Load Features	Load Features	●	●	●	●
	Four Quadrant Powers	Four Quadrant Powers	●	●	●	●	
	ENERGY & DEMAND	Energy	Ep_imp, Ep_exp, Ep_total, Ep_net, Epa_imp, Epa_exp, Epb_imp, Epb_exp, Epc_imp, Epc_exp	●	●	●	●
		Reactive Energy	Eq_imp, Eq_exp, Eq_total, Eq_net, Eqa_imp, Eqa_exp, Eqb_imp, Eqb_exp, Eqc_imp, Eqc_exp	●	●	●	●
		Apparent Energy	Es, Esa, Esb, Esc	●	●	●	●
Demand		Dmd_P, Dmd_Q, Dmd_S, Dmd_I1, Dmd_I2, Dmd_I3	●	●	●	●	
TOU	TIME OF USE	Energy/max demand	TOU, 4 Tariffs, 12 Seasons, 14 Schedules			●	
	DAYLIGHT SAVING TIME	Two Adjustable Formats	Month/Day/Hour/Minute Month/Week/First few weeks/Hour/Minute			●	
MONITORING	WAVEFORM CAPTURE	Voltage and Current Waveform	Trigger, Manual, DI change, Sag/Dips, Swell, Over Current				●
	POWER QUALITY	Voltage Unbalance Factor	U_unbl	●	●	●	●
		Current Unbalance Factor	I_unbl	●	●	●	●
		Voltage THD	THD_V1, THD_V2, THD_V3, THD_Vavg	●	●	●	●
		Current THD	THD_I1, THD_I2, THD_I, THD_Iavg	●	●	●	●
		Individual Harmonics	Harmonics 2 <sup>nd</sup> to 63 <sup>rd</sup> (50H or 60Hz) Harmonics 2 <sup>nd</sup> to 15 <sup>th</sup> (400Hz)	●	●	●	●
		Voltage Crest Factor	Crest Factor	●	●	●	●
		TIF	THFF	●	●	●	●
	Current K factor	K Factor	●	●	●	●	
	STATISTICS	MAX with Time Stamp MIN with Time Stamp	Each phase of V & I; Total of P, Q, S, PF & F; Demand of I1, I2, I3, P, Q&S; Each phase THD of V & I; Unbalance factor of V & I	●	●	●	●
OTHERS	ALARM	Over/Under Limit Alarm	V, I, P, Q, S, PF, V_THD & I_THD Each Phase and Total or Average; Unbalance Factor of V & I; Load Type; Analog Input of Each Channel; Demand of I1, I2, I3, P, Q&S; Reverse phase sequence; DI1~DI28	●	●	●	●
	POWER QUALITY EVENT LOGGING	Sag/Dips, Swell	Voltage				●
	DATA LOGGING	Data Logging 1 Data Logging 2 Data Logging 3	F, V1/2/3/lnavg, V12/23/13/lavg, I1/2/3/n/avg, P1/2/3/sum, Q1/2/3/sum, S1/2/3/sum, PF1/2/3, PF, U_unbl, I_unbl, Load Type, Ep_imp, Ep_exp, Ep_total, Ep_net, Eq_imp, Eq_exp, Eq_total, Eq_net, Es, Epa_imp, Epa_exp, Epb_imp, Epb_exp, Epc_imp, Epc_exp, Eqa_imp, Eqa_exp, Eqb_imp, Eqb_exp, Eqc_imp, Eqc_exp, Esa, Esb, Esc, THD_V1/2/3/avg, THD_I1/2/3/avg, Harmonics 2 <sup>nd</sup> to 63 <sup>rd</sup> , Crest Factor, THFF, K Factor, Sequence and Phase Angles, DI Counter, AI, AO, Dmd P/Q/S, Dmd I1/2/3		●	●	●
	ONBOARD MEMORY SIZE	Memory	Bytes	—	8MB	8MB	16MB
	COMMUNICATION	RS485 Port, Half Duplex, Optical Isolated	Modbus®-RTU Protocol/DNP3.0 Option	●	●	●	●
TIME	Real Time Clock	Year, Month, Date, Hour, Minute, Second	●	●	●	●	

CATEGORY		ITEM	PARAMETERS	Acuvim II	Acuvim IIR	Acuvim IIE	Acuvim IIW
OPTION MODULE	I/O OPTION	Switch Status (DI)	Digital Input (Wet)	⊙	⊙	⊙	⊙
		Power Supply for DI	24 Vdc	⊙	⊙	⊙	⊙
		Relay Output (RO)	NO, Form A	⊙	⊙	⊙	⊙
		Digital Output (DO)	Photo-MOS	⊙	⊙	⊙	⊙
		Pulse Output (PO)	By Using DO	⊙	⊙	⊙	⊙
		Analog Input (AI)	0(4)~20mA, 0(1)~5V	⊙	⊙	⊙	⊙
	COMMUNICATION	Analog Output (AO)	0(4)~20mA, 0(1)~5V	⊙	⊙	⊙	⊙
		Ethernet	10M/100M, Modbus-TCP, HTTP Webpage, Email	⊙	⊙	⊙	⊙
		Profibus-DP	Profibus-DP/V0	⊙	⊙	⊙	⊙
		BACnet	IP or MS/TP	⊙	⊙	⊙	⊙
400Hz TYPE	RS485 Module	Additional Modbus RTU	⊙	⊙	⊙	⊙	
	400Hz TYPE	Only support full-wave energy, support 2 <sup>nd</sup> ~15 <sup>th</sup> individual harmonics	⊙	⊙	⊙		

## Digital/Analog I/O

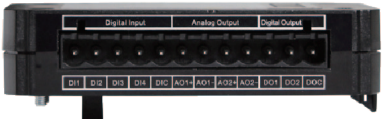
Integrate data to/from other devices with field expandable plug-in I/O modules

AXM-IO1	AXM-IO2	AXM-IO3
		
6x digital inputs 24Vdc power for digital inputs 2x relay outputs	4x digital inputs 2x digital outputs 2x analog outputs	4x digital inputs 2x relay outputs 2x analog inputs

## Communications Protocols

A standard RS-485 port and our AXM line of plug-in expansions modules support a wide array of protocols.

	Standard	AXM-NET	AXM-NET-P	AXM-BMS	AXM-BIP	AXM-PROFI	AXM-RS485
MODBUS-RTU	•						•
DNP 3.0	•						
MODBUS-TCP		•	•				
HTTP Webserver		•	•				
SMTP Email		•	•				
HTTP Push			•				
BACnet-MS/TP				•			
BACnet-IP					•		
PROFIBUS						•	

## SPECIFICATIONS

METERING			
Parameters	Accuracy	Resolution	Range
Voltage	0.2%	0.1V	10V~1000kV
Current	0.2%	0.1mA	5mA~50000A
Power	0.2%	1W	-9999MW~9999MW
Reactive Power	0.2%	1var	-9999Mvar~9999Mvar
Apparent Power	0.2%	1VA	0~9999MVA
Power Demand	0.2%	1W	-9999MW~9999MW
Reactive Power Demand	0.2%	1var	-9999Mvar~9999Mvar
Apparent Power Demand	0.2%	1VA	0~9999MVA
Power Factor	0.2%	0.001	-1.000~1.000
Frequency	0.2%	0.01Hz	45.00~65.00Hz (50 or 60Hz type) 300.00Hz~500.00Hz (400Hz type)
Energy	Primary	0.2%	0.1kWh
	Secondary	0.2%	0.001kWh
Reactive Energy	Primary	0.2%	0.1kvarh
	Secondary	0.2%	0.001kvarh
Apparent Energy	Primary	0.2%	0.1kVAh
	Secondary	0.2%	0.001kVAh
Harmonics	1.0%	0.1%	
Phase Angle	2.0%	0.1°	0.0°~359.9°
Unbalance Factor	2.0%	0.1%	0.0%~100.0%
Running Time		0.01h	0~999999.99h



**INPUT****Current Inputs (Each Channel)**

Nominal Current	① 5A, ② 1A, ③ 1A(333mV), ④ 1A(100mV Rope-CT), ⑤ 1A(80mA/100mA/200mA)
Metering Range	① 0~10A, ② 0~2A, ③ 0~1.2A, ④ 0~1.2A, ⑤ 0~1.2A
Pickup Current	① 5mA, ② 1mA, ③ 5mA, ④ 5mA, ⑤ 5mA,
Withstand	20Arms Continuous, 0.1% of Nominal 100Arms for 1 second, Non-Recurring
Burden	0.05VA (Typical) @ 5Arms
Accuracy	0.2% Full Scale

**Voltage Inputs (Each Channel)**

Nominal Full Scale	400Vac L-N, 690Vac L-L (+20%)
Withstand	1500Vac Continuous
Input Impedance	2500Vac, 50/60Hz for 1 Minute
Metering Frequency	2Mohm per Phase
Pickup Voltage	45Hz~65Hz, 300Hz ~ 500Hz
Accuracy	10Vac 0.2% Full Scale

**Energy Accuracy**

Active	Class 0.2s (According to IEC 62053-22) Class 0.2s (According to ANSI C12.20)
Reactive	Class 2 (According to IEC 62053-23)

**Harmonic Resolution**

Metered Value	63 <sup>rd</sup> Harmonic (50Hz or 60Hz type) 15 <sup>th</sup> Harmonic (400Hz type)
---------------	---

**COMMUNICATION****RS-485 (Standard)**

MODBUS® RTU and DNP 3.0  
2 Wire Shielded Twisted Pair Cable Connection  
Baud Rate:1200~38400 bps

**The Second RS-485 Port (Optional)**

(The Same as RS-485 Standard Contents)  
Baud Rate: 4800~38400 bps

**Ethernet (Optional)**

10M/100M BaseT  
MODBUS® TCP, SNMP, HTTP Push  
Webpage Data Browsing Through HTTP Send email Based on Timer or Triggered Event

**PROFIBUS (Optional)**

PROFIBUS-DP/V0 Protocol  
Work as PROFIBUS Slave, Baud Rate Adaptive, up to 12M  
Model 1 : Input Bytes:32,Output Bytes:32  
Model 2: Input Bytes :64,Output Bytes:2  
PROFIBUS Standard According to EN 50170 Vol.2

**BACnet(Optional)**

BACnet IP, BACnet MS/TP

**STANDARD COMPLIANCE**

Measurement Standard	IEC 62053-22; ANSI C12.20
Environmental Standard	IEC 60068-2
Safety Standard	IEC 61010-1, UL 61010-1, IEC 61557-12
EMC Standard	IEC 61000-4/-2-3-4-5-6-8-11, CISPR 22, IEC 61000-3-2, IEC 61000-6-2/4
Outlines Standard	DIN 43700, ANSI C39.1

**I/O OPTION****Digital Input**

Input Voltage Range	20~160 Vac/dc
Input Current (Max)	2mA
Start Voltage	15V
Stop Voltage	5V
Pulse Frequency (Max)	100Hz, 50% Duty Ratio (5ms ON and 5ms OFF)
SOE Resolution	2ms

**Digital Output (DO) (Photo-MOS)**

Voltage Range	0~250Vac/dc
Load Current	100mA (Max)
Output Frequency	25Hz, 50% Duty Ratio (20ms ON, 20ms OFF)
Isolation Voltage	2500Vac

**Relay Output (RO)**

Switching Voltage (Max)	250Vac, 30Vdc
Load Current	5A(R), 2A(L)
Set Time	10ms (Max)
Contact Resistance	30mΩ (Max)
Isolation Voltage	2500Vac
Mechanical Life	1.5x10 <sup>7</sup>

**Analog Output (AO)**

Output Range	0~5V/1~5V, 0~20mA/4~20mA (Optional)
Accuracy	0.5%
Temperature Drift	50ppm/°C Typical
Isolation Voltage	500Vdc
Open Circuit Voltage	15V

**Analog Input (AI)**

Input Range	0~5V/1~5V, 0~20mA/4~20mA (Optional)
Accuracy	0.2%
Temperature Drift	50ppm/°C Typical
Isolation Voltage	500Vdc

**Power Supply for DI (24Vdc)**

Output Voltage	24Vdc
Output Current	42mA
Load (Max)	21 DIs

**CONTROL POWER**

Universal AC or DC

**AC/DC Control Power**

Operating Range	100~415Vac, 50/60Hz; 100~300Vdc
Burden	5W
Frequency	50/60Hz
Withstand	3250Vac, 50/60Hz for 1 minute
Installation Category III (Distribution)	

**Low Voltage DC Control Power (Optional)**

Operating Range	20~60Vdc
Burden	5W

**OPERATING ENVIRONMENT**

Operation Temperature	- 25°C to 70°C
Storage Temperature	- 40°C to 85°C
Relative Humidity	5% to 95% Non-Condensing

# TYPICAL WIRING

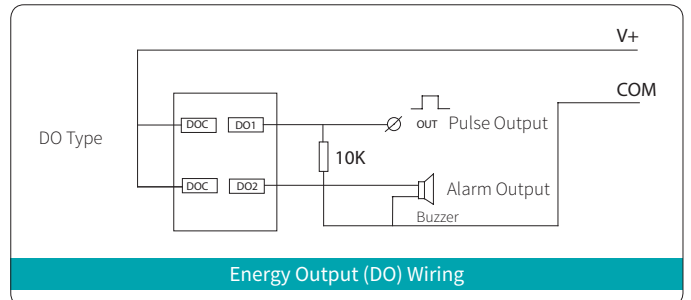
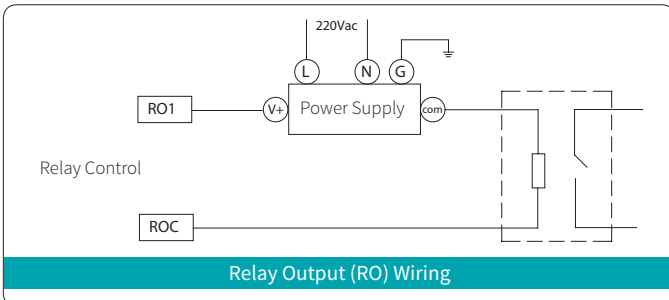
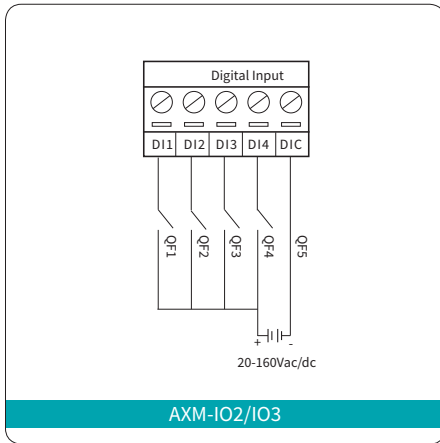
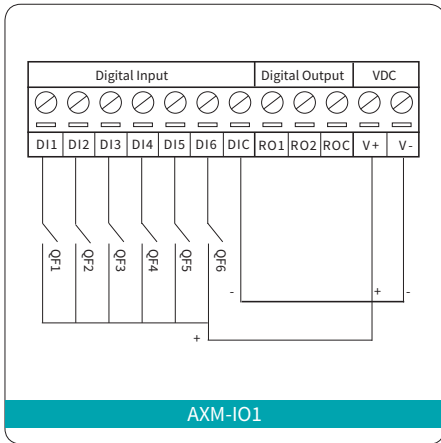
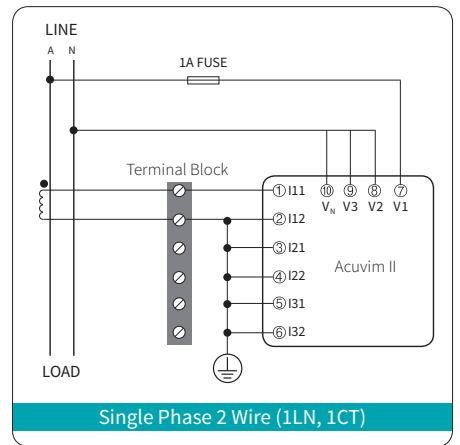
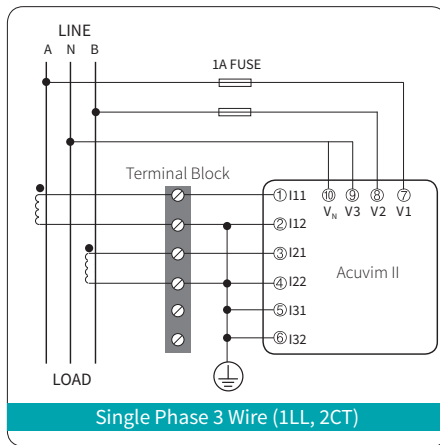
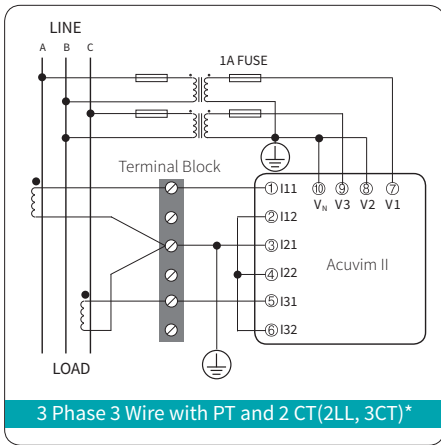
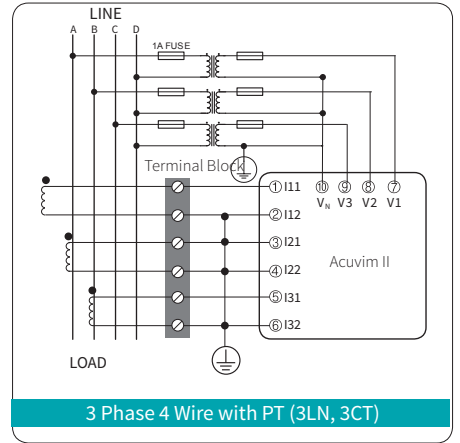
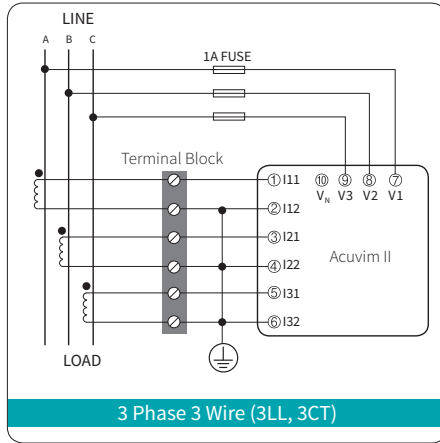
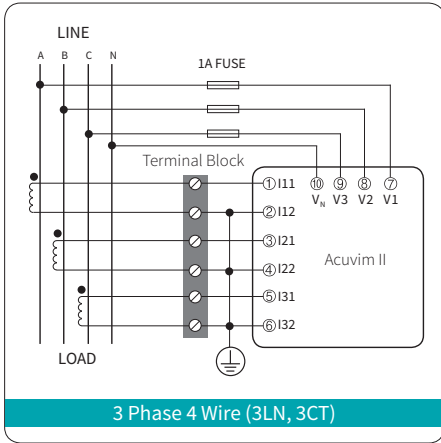

\*Note: 2CT configuration is optional only in 3 Phase 3 Wire system.

# DIMENSIONS

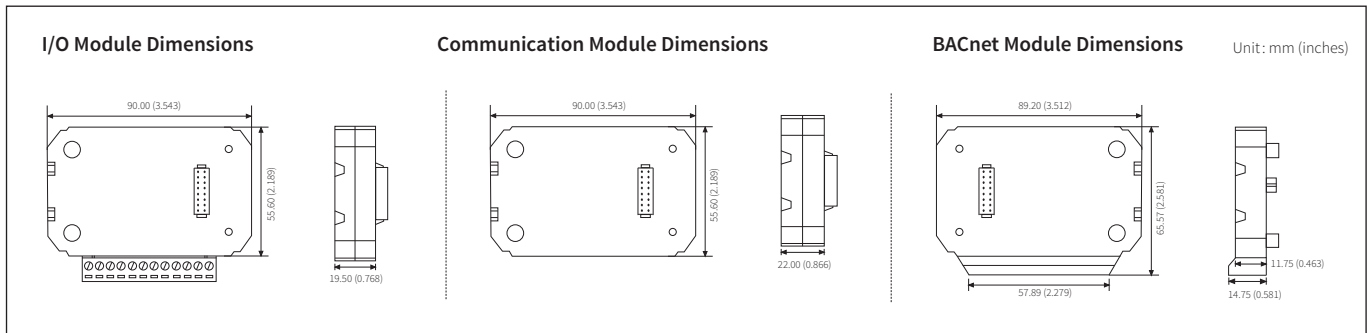
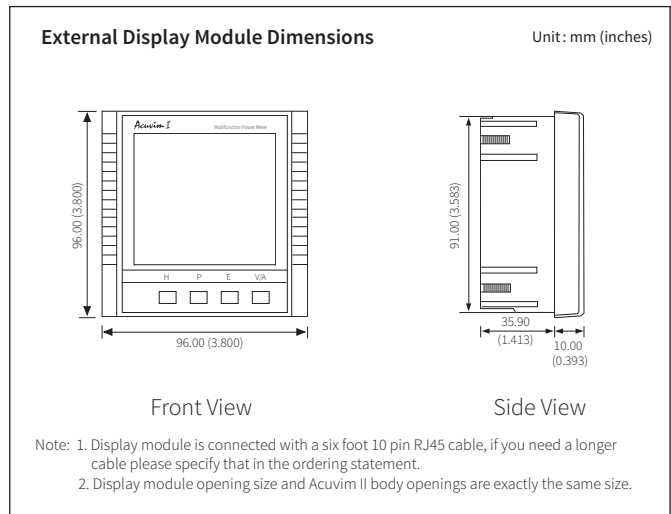
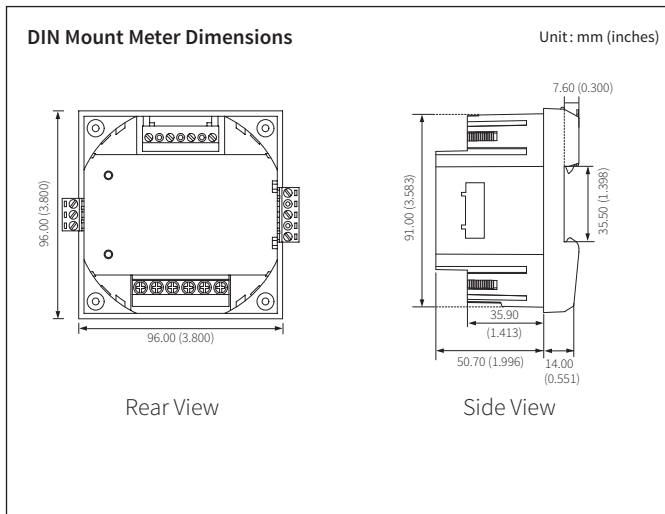
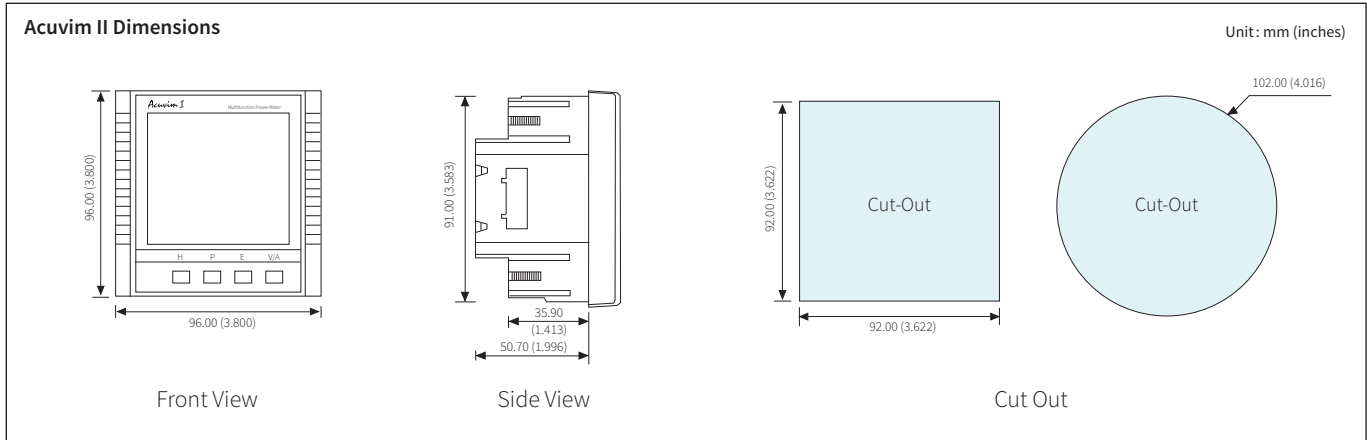

# ROGOWSKI COIL

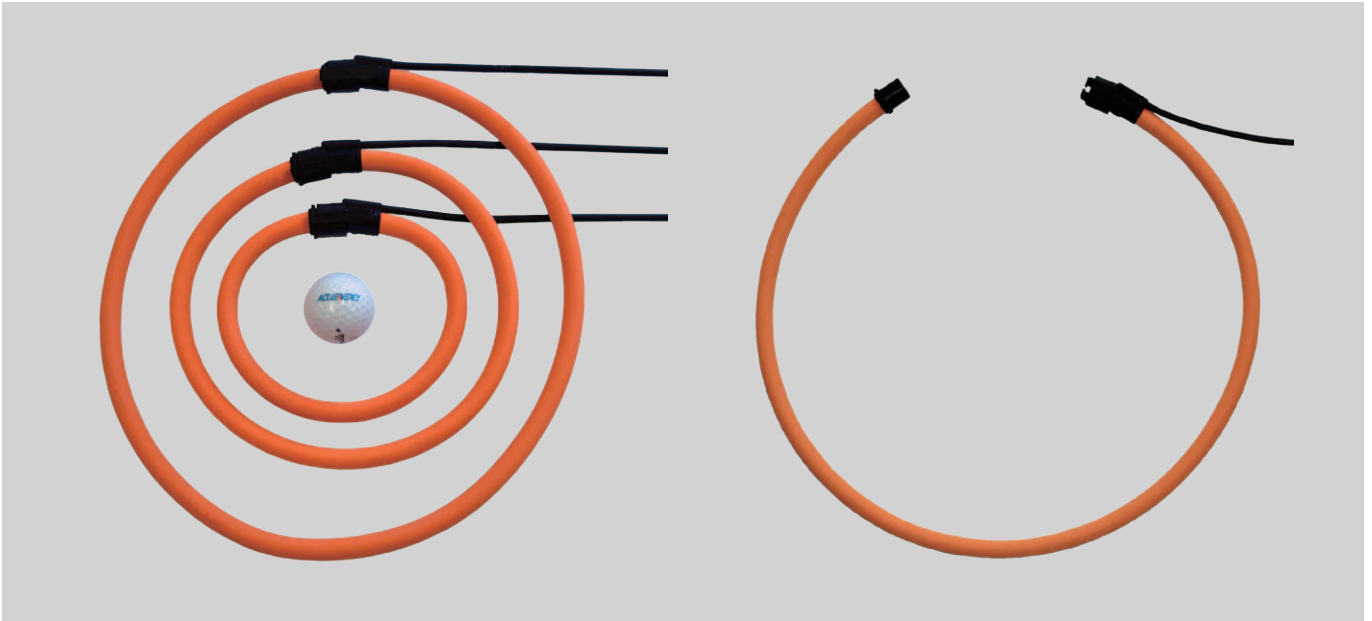

Accuenergy's flexible Rogowski coil is designed for use where regular solid or split core current transformers cannot fit, and is ideal for power quality monitoring such as harmonics. Advantages of the Rogowski coil include; high accuracy, wide measurement and frequency range with no additional integrator or power supply needed.

Specification	
Window Size	106mm (4.17"), 178mm (7.01"), 271mm (10.67"), 369mm (14.53")
Length of Coil	400mm (15.75"), 600mm (23.62"), 900mm (35.43"), 1200mm (47.24")
Current Input Ranges*	5A-1200A 12.5A-3000A 25A-6000A 50A-12000A 250A-50000A
Frequency Range	20Hz - 5kHz
Accuracy	0.5% at any point
Lead	White-Positive, Brown-Negative, Bare-Shield; 24AWG
Polarity	Arrow Towards Load (Current Flow Direction)
Operating Temperature	-20°C - 70°C
Temperature Drift	+/- 0.07% Within Operating Temperature Range
Material	Orange Thermoplastic Rubber, Flame Retardant UL 94 V-0 Rated
Dielectric Strength	7400Vac @ 50/60Hz for 1 Minute

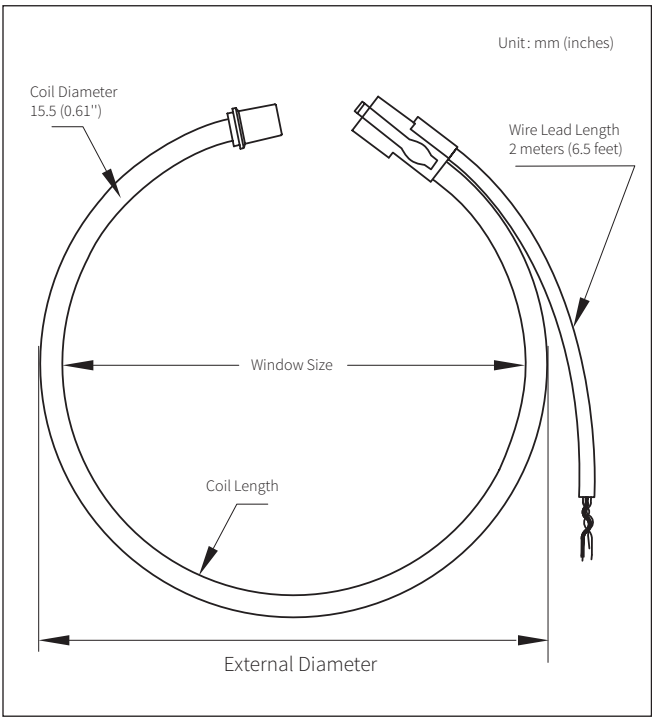

Dimensions mm (Inch)	RCT16	RCT24	RCT36	RCT47
Window Size	106 (4.17")	178 (7.01")	271 (10.67")	369 (14.53")
Coil Length	400mm (15.75")	600mm (23.62")	900mm (35.43")	1200mm (47.24")
External Diameter	143 (5.63")	207 (8.13")	302 (11.89")	398 (15.66")
Coil Diameter	15.5 (0.61")			
Wire Lead Length	2 meters (6.5 feet)			

\*Note: Listed ranges are standard input ranges, for any other current input ranges please contact Accuenergy.

# SPLIT CORE CTS

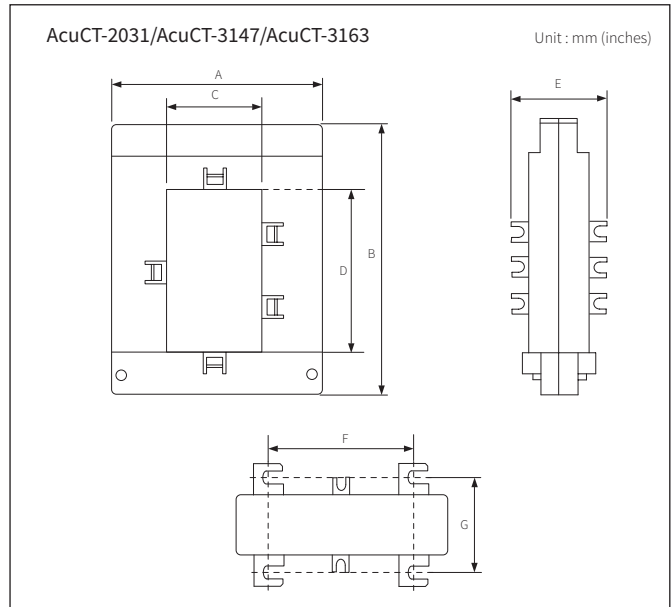
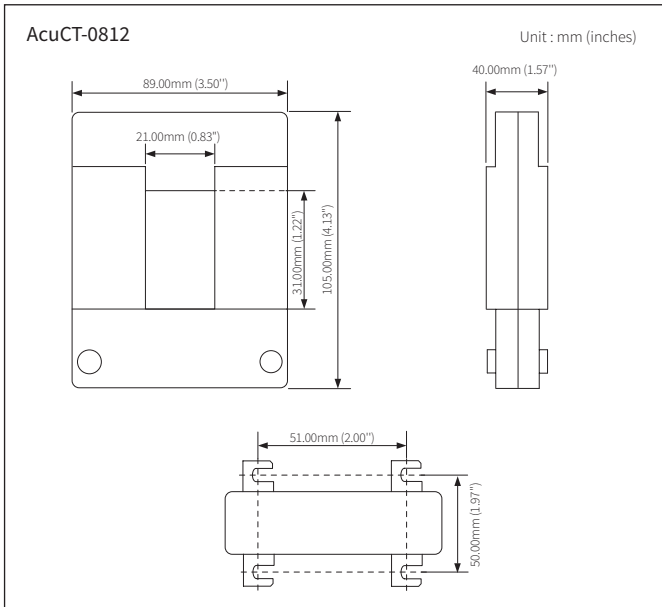

Model	A	B	C	D	E	F	G
AcuCT-2031	114.00(4.49")	145.00(5.71")	50.00(1.97")	80.00(3.15")	50.00(1.97")	78.00(3.07")	50.00(1.97")
AcuCT-3147	144.00(5.67")	185.00(7.28")	80.00(3.15")	120.00(4.72")	50.00(1.97")	108.00(4.25")	50.00(1.97")
AcuCT-3163	176.00(6.93")	247.00(9.72")	80.00(3.15")	160.00(6.30")	70.00(2.76")	120.00(4.72")	50.00(1.97")

# ORDERING INFORMATION

	Model	Mounting Option	Current Input	Power Supply
<b>Ordering Number</b>	-	-	-	-
<b>Ordering Example</b>	Acuvim IIE	D	5A	P1
	Acuvim II: Basic Model	D: Intergrated with LCD Display (Panel Mount Meter/Transducer)	5A: 5A Input	P1: 100~415Vac, 50/60Hz 100~300Vdc
	Acuvim IIR: II + Data Logging	M: Din-Rail Mount Transducer without Display (Optional Remote Display Available)	1A: 1A Input	P2: 20~60Vdc
	Acuvim IIE: IIR + Time of Use		80mA: 80mA Input	
	Acuvim IIW: IIR + Waveform Capture and PQ Event Logging		100mA: 100mA Input	
			200mA: 200mA Input	
			RCT: Rogowski Coil Input (Coil to be Ordered Separately from Below)	
			333: 333mV Input	

- Note: 1. Accuenergy suggests using USB-RS485 converter for configuration, and 3 CTs per three phase circuits.  
 2. All fields must be completed to create a part number.  
 3. Add "-S" after power supply for anti-tampering seal option.  
 4. Contact Accuenergy for 400Hz frequency option; 400Hz type, it don't support Acuvim IIW.

### I/O Option module:

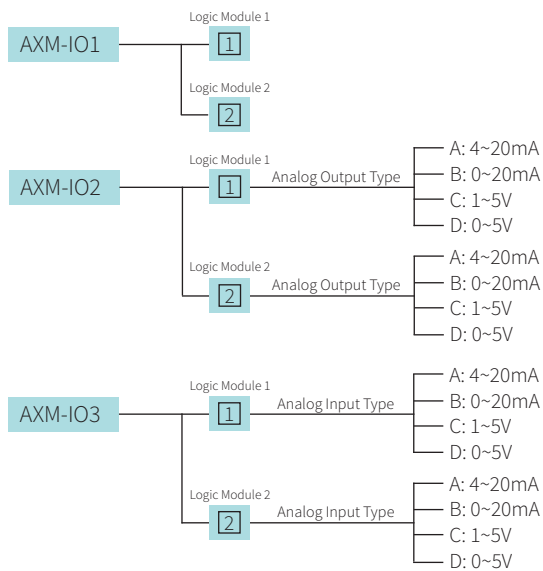

I/O Module Ordering Example: AXM-IO2-1A

### Remote Display Option:

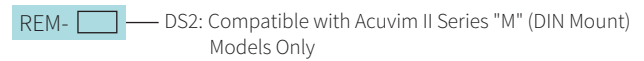

### Communication Option Module:

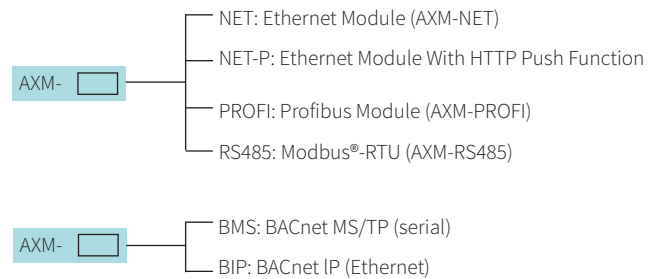

- Note: 1. No more than 2 of the same I/O modules may be attached to the meter (example: Two AXM-IO2). The same two I/O modules must have a different logic number.  
 2. A maximum of 3 modules may be attached to the meter. If a communication module is used (example: AXM-NET), it must be installed on the back FIRST before the other modules are attached.  
 3. If Acuvim IIW uses DI to trigger a waveform capture, the I/O module logic number must be Module 1.

**Rogowski Coil Ordering Information:**

	Size	Current Range
Ordering Number	-	-
Ordering Example	RCT16	- 1000
	RCT16 : 15.75" Coil, 4" Diameter	1000: Metering Range 5A to 1200A
	RCT24 : 23.62" Coil, 7" Diameter	2500: Metering Range 12.5A to 3000A
	RCT36: 35.43" Coil, 10.67" Diameter	5000: Metering Range 25A to 6000A
	RCT47: 47.24" Coil, 14.5" Diameter	10000: Metering Range 50A to 12000A
		50000: Metering Range 250A to 50000A

Note:1. Make sure maximum current rating in system being metered is within the current metering range for Rogowski coil.  
 2. Please contact Accuenergy if other lengths of coil or current ranges are needed.

## Additional Accessories

**AcuPanel ordering information:**

AcuPanel 9014 (NEMA4 Indoor Panel)  
 AcuPanel 9104X (NEMA4X Waterproof)

**Split Core CT Ordering Information:**

	Model	Rated Input	Output
Ordering Number	-	-	-
Ordering Example	AcuCT-2031	- 600	- 5
	AcuCT-0812	- 250	- 5
		200: 200A	5: 5A Input
		250: 250A	
		300: 300A	
		400: 400A	
	AcuCT-2031	- 400	- 5
		400: 400A	5: 5A Input
		600: 600A	
		800: 800A	
		1000: 1000A	
	AcuCT-3147	- 1000	- 5
		1000: 1000A	5: 5A Input
		1200: 1200A	
		1600: 1600A	
	AcuCT-3163	- 2000	- 5
		2000: 2000A	5: 5A Input
		2500: 2500A	
		3000: 3000A	
		4000: 4000A	
		5000: 5000A	

Note: Please contact Accuenergy if CTs in other sizes and ratios are needed.



Make Energy Usage Smarter



**Accuenergy (Canada) Inc**

2 Lansing Square, Suite 1001  
Toronto, ON M2J 4P8, Canada



**Accuenergy Pacific Automation Company Ltd.**

400 Continental Blvd., Suite 600  
El Segundo, CA 90245, USA



**Beijing Accuenergy Technology Co, Ltd.**

NO. 12 Fengrun East Road, Yongfeng Industrial Park  
Haidian District, 100094 Beijing China



+66 809 5588



[www.amptronth.com](http://www.amptronth.com)



[sales@amptron.th.com](mailto:sales@amptron.th.com)